

ITEM 項目	PARTS NAME 零件名稱	Q'TY 數量	MATERIAL 材質	FINISH/REMARK 處理/備註
1	TOP COVER	1	A.B.S	(Black)
2	BOTTOM COVER	1	A.B.S	(Black)
3	HOUSING	1	P.B.T+G.F	UL-94V-0 (Black)
4	BUTTON	2	A.B.S	(Black)
5	LATCH	1	STAINLESS	Non-plating
6	TOP SHELL	1	STAINLESS	Non-plating
7	CONTACT	20	Phosphor Bronze	Gold flash selective

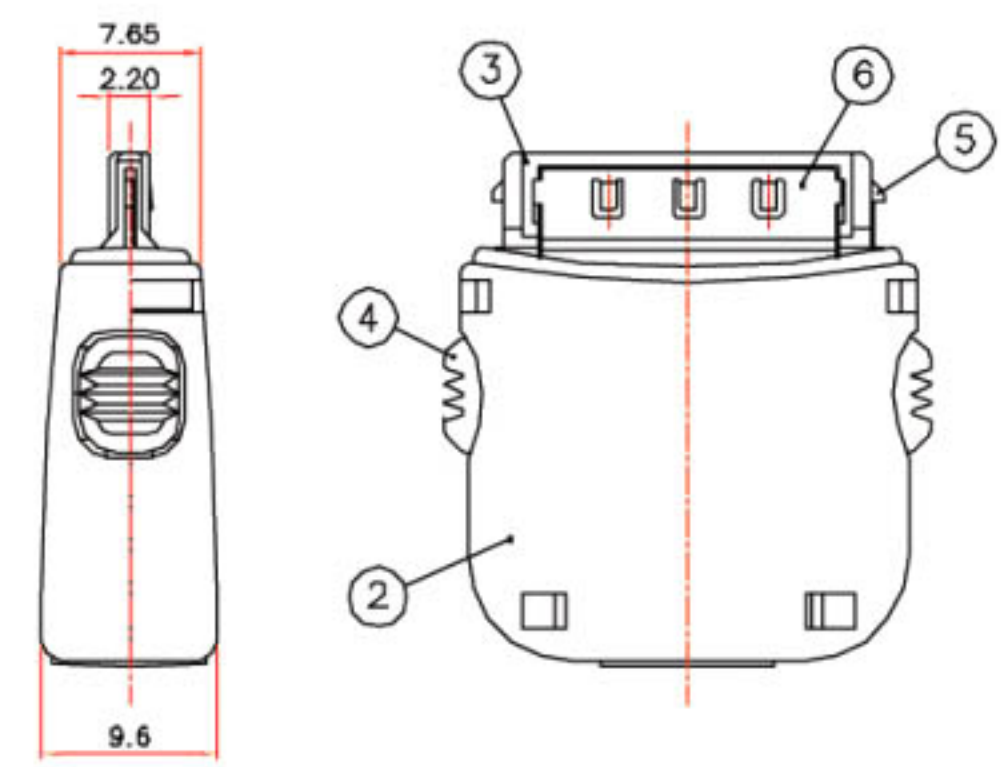

SPECIFICATION
MATERIAL
 See drawing
STANDARD DATA
 Rating current: 1.0A
 Applicable wire: AWG#26 Max.
 Operating temperature: -30°C ~ +80°C
 Storage temperature: -40°C ~ +85°C
ELECTRICAL
 Insulator resistance: 1000M ohms Min. @ 250 VDC
 Withstanding voltage: 100 VAC / minute
 Contact resistance: 50 m ohms Max.
MECHANICAL
 Mating force: 30N(3.06kgf) Max.
 Unmating force (Without lock): 4.2N(0.43kgf) Min.
 Durability: 10000 cycles Min.
 Contact retention force: 4.2N(0.43kgf) Min
PART NO.

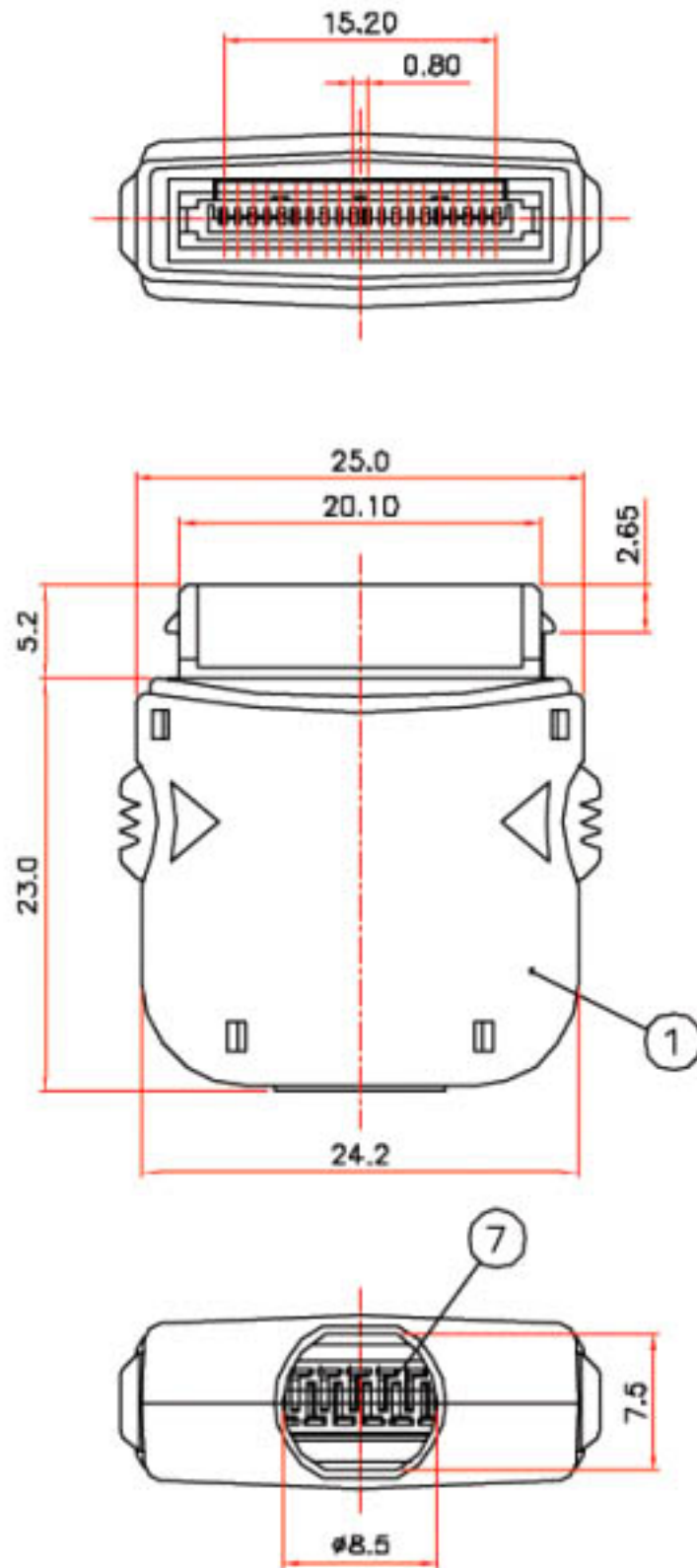
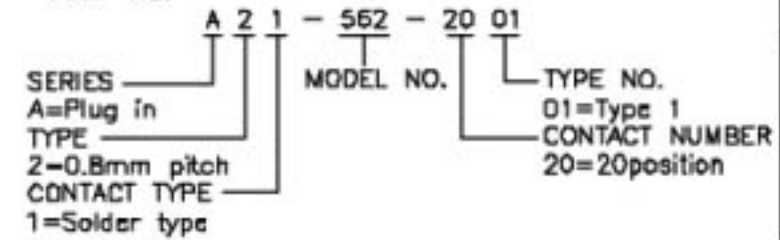

CYPRESS INDUSTRIES
 www.cypressindustries.com

REV.	ECN NO.	MARK	REVISIONS	SIGN	DATE	UNLESS OTHERWISE SPECIFIED TOLERANCE	CHECKED	DESIGNED	TITLE	SCALE	PART NO.	REV.
版本	改變號碼	記號	改變內容	修改	日期	尺寸公差	審核	設計	產品名稱	比例	產品料號	版本
A	EXXXX-XXX	△ x 0	-	-	-	X. ±0.50 .X ±0.30 .XX ±0.20 ANG. ±5°00'	APPROVED	DRAWN	Plug in connector Solder type-20 position	2.5/1	A21-562-2001	A
											CUT-562-001	