

ITEM 項目	PARTS NAME 零件名稱	Q'TY 數量	MATERIAL 材質	FINISH/REMARK 處理/備註
1	TOP COVER	1	A.B.S	(Black)
2	BOTTOM COVER	1	A.B.S	(Black)
3	HOUSING	1	P.B.T+G.F	UL-94V-0 (Black)
4	LATCH	1	STAINLESS t=0.30	Non-plating
5	CONTACT	5	Phosphor Bronze t=0.20	Gold flash selective

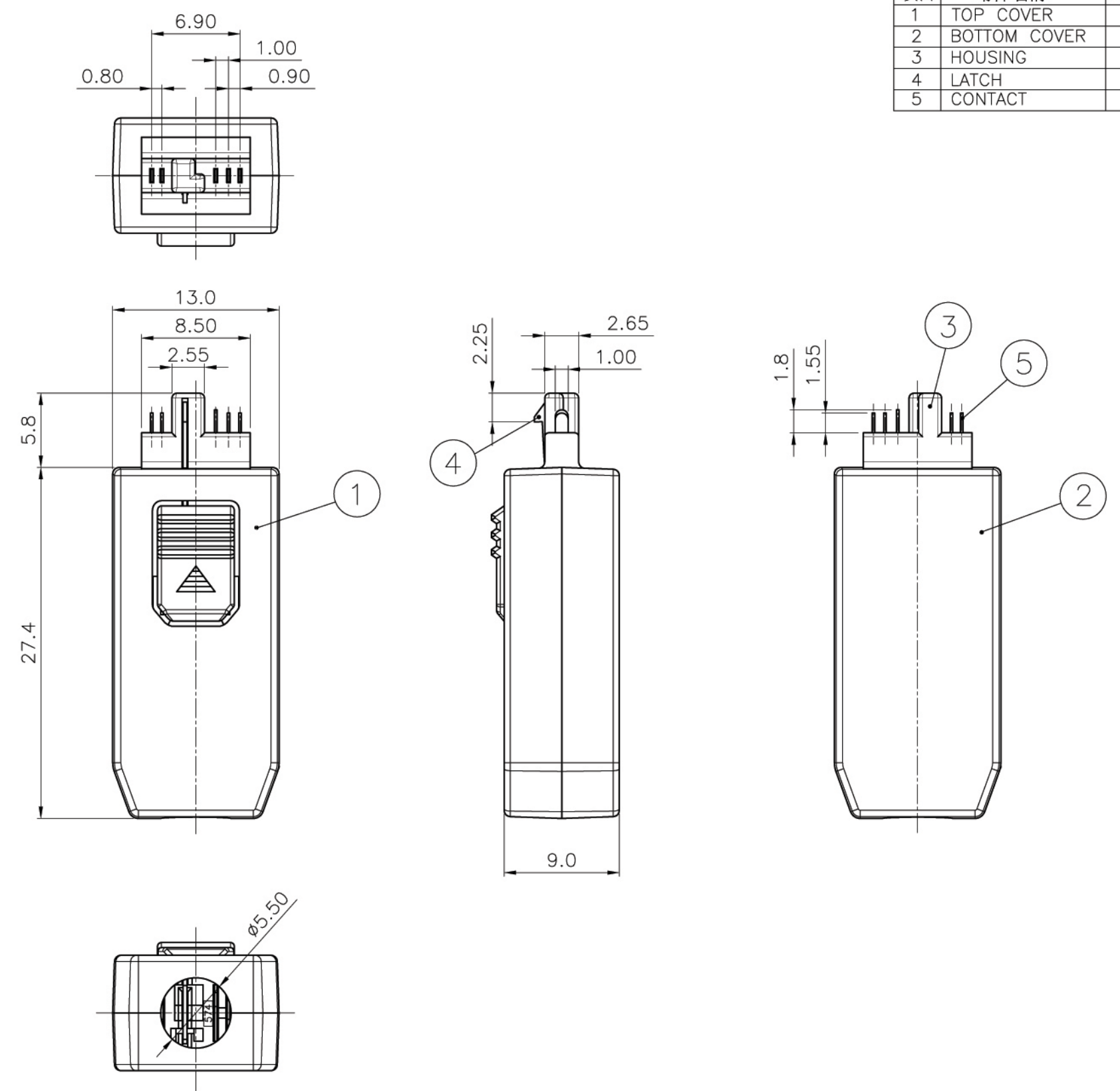

SPECIFICATION

MATERIAL
See drawing

STANDARD DATA
Rating current: 1.0A
Applicable wire: AWG#26 Max.
Operating temperature: -30°C ~ +60°C
Storage temperature: -40°C ~ +85°C

ELECTRICAL
Insulator resistance: 1000M ohms Min. @ 250 VDC
Withstanding voltage: 100 VAC / minute
Contact resistance: 130 m ohms Max.

MECHANICAL
Mating force: 30N(3.06kgf) Max.
Unmating force (Without lock): 4.2N(0.43kgf) Min.
Durability: 10000 cycles Min.
Contact retention force: 4.2N(0.43kgf) Min

PART NO.

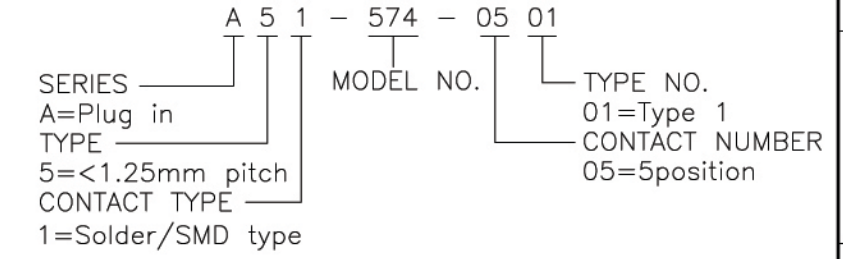

Cypress Industries
www.cypressindustries.com

UNLESS OTHERWISE SPECIFIED TOLERANCE 尺寸公差		CHECKED 審核	DESIGNED 設計 H.T.CHEN 11/13/01'	TITLE 產品名稱 PLUG IN CONNECTOR		
X. ±0.50		APPROVED 承認	DRAWN 製圖 H.T.CHEN 11/13/01'	UNIT 單位 MM	PART NO. 產品料號 CCA51-574-0501	
.X ±0.30				SCALE 比例 2.5/1		DOC. NO. 文件編號 CUT-574-001
.XX ±0.20				SIZE 尺寸 A3		
ANG. ±5°00'						
REV. 版本	ECN NO. 設變號碼	MARK 記號	REVISIONS 設變內容	SIGN 修改	DATE 日期	
1	2	3	4	5	6	